

ResMed

HumidAir™



User guide
English

Welcome

HumidAir™ is a humidifier that provides heated humidification and is designed for use with your AirSense™ 10 or AirCurve™ 10 device.

Read this guide together with your AirSense 10 or AirCurve 10 device user guide.

Setup

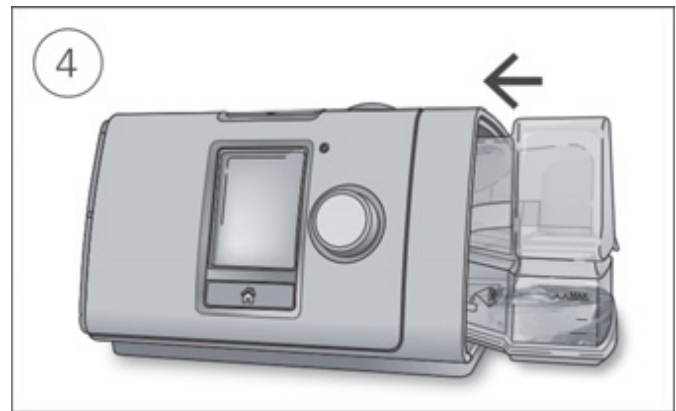
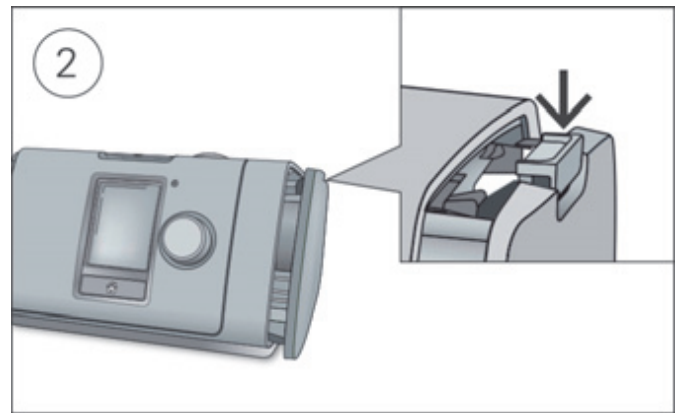

CAUTION

Do not overfill the humidifier as water may enter the device and air tubing.

1. Place the device on a stable level surface.
2. Remove the side cover from the device by pressing the clip of the side cover and pulling it away from the device.
3. Open the humidifier and fill it with water up to the maximum water level mark.
Do not fill the humidifier with hot water.
4. Close the humidifier and insert it into the side of the device.
Your device is now ready to be used with humidification. See **Humidity Level** to change your settings.

For more information on how to setup your device, turn on therapy or change settings refer to your device user guide.

Recommended water type (France only)

The following water types are recommended for use in the humidifier:

- Boiled tap water, cooled to room temperature
- Distilled water
- Bottled water (with a low mineral content).

Note: Do not use non-sterile demineralised water for domestic use.

Humidity Level

The humidifier moistens the air and is designed to make therapy more comfortable. If you are getting a dry nose or mouth, turn up the humidity. If you are getting any moisture in your mask, turn down the humidity.

You can set the Humidity Level to Off or between 1 and 8, where 1 is the lowest humidity setting and 8 is the highest humidity setting.



To adjust the Humidity Level:

1. Enter **My Options**, turn the dial to highlight **Humidity Level** and then press the dial.
2. Turn the dial to adjust the humidity level and press the dial to save the change.

If you continue to get a dry nose or mouth, or moisture in your mask, consider using ClimateLineAir heated air tubing. ClimateLineAir together with Climate Control delivers more comfortable therapy.

Removing the humidifier

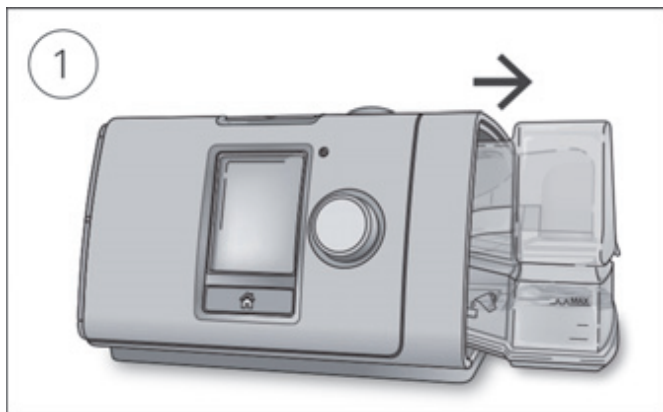

1. Hold the humidifier at the top and bottom, press it gently and pull it away from the device.
2. Open the humidifier and discard any remaining water.

Cleaning

You should clean the humidifier weekly as described.

1. Wash the humidifier in warm water using mild detergent.

2. Rinse the humidifier thoroughly and allow to dry out of direct sunlight and/or heat.
3. Before re-inserting the humidifier into the device, open the humidifier and fill it with water up to the maximum water level mark.

Notes:

- Empty the humidifier daily and wipe it thoroughly with a clean, disposable cloth. Allow to dry out of direct sunlight and/or heat.
- The humidifier may be washed in a dishwasher on the delicate or glassware cycle (top shelf only). It should not be washed at temperatures higher than 65°C.

Checking

You should regularly check the humidifier for any damage.

- Replace it if it is leaking or has become cracked, cloudy or pitted.
- Replace it if the seal is cracked or torn.
- Remove any white powder deposits using a solution of one part household vinegar to 10 parts water.

Travelling

You can take your AirSense 10 device with you wherever you go. Just make sure you empty the humidifier and pack it separately in the travel bag.

Travelling by plane

Your AirSense 10 device may be taken on board as carry-on luggage. Medical devices do not count toward your carry-on luggage limit.

When using the device on a plane:

- Make sure the humidifier is completely empty and inserted into your device. Alternatively, reattach the side cover.
- Turn on **Airplane Mode**.

CAUTION

Do not use the device with water in the humidifier on a plane due to the risk of inhalation of water during turbulence.

Troubleshooting

If you have any problems, have a look at the following troubleshooting topics. If you are not able to fix the problem, contact your care provider or ResMed. Do not try to open the device.

General troubleshooting

Problem/possible cause	Solution
I am getting a dry or blocked nose	
Humidity level may be set too low.	Adjust the Humidity Level. If you have ClimateLineAir heated air tubing, see the ClimateLineAir user guide.
I am getting droplets of water on my nose, in the mask and air tubing	
Humidity level may be set too high.	Adjust the Humidity Level. If you have ClimateLineAir heated air tubing, see the ClimateLineAir user guide.
My mouth is very dry and uncomfortable	
Air may be escaping through your mouth.	Increase the Humidity Level. You may need a chin strap to keep your mouth closed or a full face mask.

Device messages

Device message/possible cause	Solution
High leak detected, check your water tub, tub seal or side cover	
Humidifier may not be inserted properly.	Make sure the humidifier is correctly inserted.
Humidifier seal may not be inserted properly.	Open the humidifier and make sure that the seal is correctly inserted.
High leak detected, connect your tubing	
Air tubing may not be connected properly.	Make sure the air tubing is firmly connected at both ends.
Mask may be fitted incorrectly.	Make sure your mask is fitted correctly. See your mask user guide for fitting instructions or use the Mask Fit function to check your mask fit and seal.
System fault, refer to user guide, Error 004	
Device may have been left in a hot environment.	Allow to cool before re-use. Disconnect the power supply and then reconnect it to restart the device.
Air filter may be blocked.	Check the air filter and replace it if there are any blockages. Disconnect the power supply and then reconnect it to restart the device.
Air tubing may be blocked.	Check the air tubing and remove any blockages. Press the dial to clear the message and then press Start/Stop to restart the device.
There may be water in the air tubing.	Empty the water from the air tubing. Disconnect the power supply and then reconnect it to restart the device.

Reassembling parts

Some parts of your device are designed to easily come off in order to avoid damage to the parts or the device. You can easily reassemble them as described below.

To insert the humidifier seal:

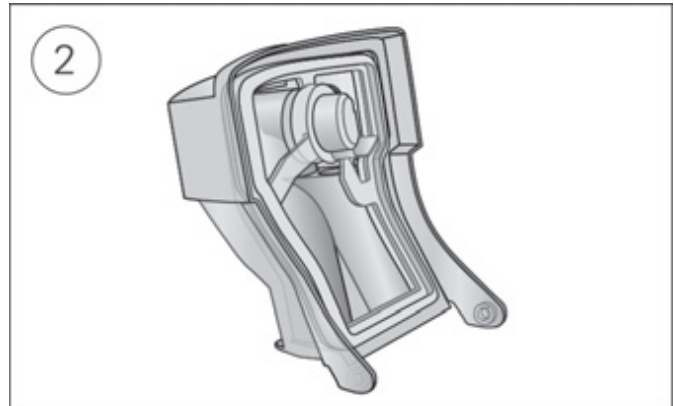
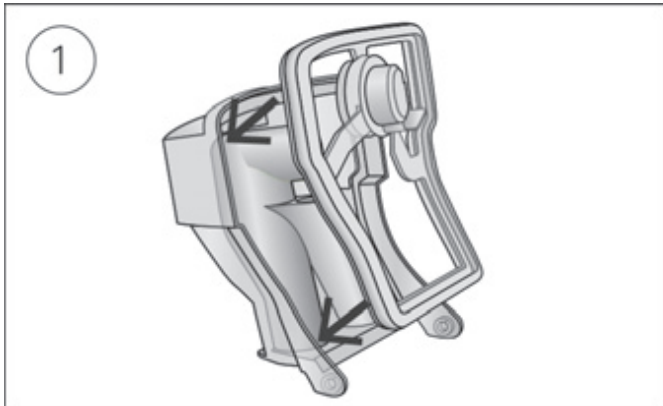

1. Place the seal into the lid.
2. Press down along all edges of the seal until it is firmly in place.

To reassemble the humidifier lid:



1. Insert one side of the lid into the pivot hole of the base.
2. Slide the other side down the ridge until it clicks into place.

General warnings and cautions

WARNING

- Beware of electrocution. Do not immerse the device, power supply or power cord in water. If liquids are spilled into or onto the device, unplug the device and let the parts dry. Always unplug the device before cleaning and make sure that all parts are dry before plugging it back in.

CAUTION

- Do not place the device on its side as water might get into the device.
- Do not use bleach, chlorine, alcohol, or aromatic-based solutions, moisturising or antibacterial soaps or scented oils to clean the device, the humidifier or air tubing. These solutions may cause damage or affect the humidifier performance and reduce the life of the products.
- If you use the humidifier, always place the device on a level surface lower than your head to prevent the mask and air tubing from filling with water.
- Leave the humidifier to cool for ten minutes before handling to allow the water to cool and to make sure that the humidifier is not too hot to touch.
- Make sure that the humidifier is empty before transporting the device.

Technical specifications

Units are expressed in cm H₂O and hPa. 1 cm H₂O is equal to 0.98 hPa.

Environmental conditions

Operating temperature:	+5°C to +35°C Note: The air flow for breathing produced by this therapy device can be higher than the temperature of the room. Under extreme ambient temperature conditions (40°C) the device remains safe.
Operating humidity:	10 to 95% relative humidity, non-condensing
Operating altitude:	Sea level to 2,591 m; air pressure range 1013 hPa to 738 hPa
Storage and transport temperature:	-20°C to +60°C
Storage and transport humidity:	5 to 95% relative humidity, non-condensing

Physical - device and humidifier

Dimensions (H x W x D):	116 mm x 255 mm x 150 mm
Air outlet (complies with ISO 5356-1:2004):	22 mm
Weight (device and cleanable humidifier):	1248 g
Housing construction:	Flame retardant engineering thermoplastic
Water capacity:	To maximum fill line 380 mL
Cleanable humidifier - material:	Injection moulded plastic, stainless steel and silicone seal

Temperature

Maximum heater plate:	68°C
Cut-out:	74°C
Maximum gas temperature:	≤ 41°C

Humidifier performance

The following settings have been tested at 71.6°F (22°C) ambient temperature:



Mask Pressure cm H ₂ O (hPa)	RH output %		Nominal system output AH ¹ , BTPS ²	
	Setting 4	Setting 8	Setting 4	Setting 8
3	85	100	6	>10
4	85	100	6	>10
10	85	100	6	>10
20	85	90	6	>10
25	85	80	6	>10



¹ AH - Absolute Humidity in mg/L



² BTPS - Body Temperature Pressure Saturated



Symbols





The following symbols may appear on the product or packaging.

 Indicates a warning or caution.
  Read instructions before use.
  Manufacturer.

 European Authorised Representative.
  Batch code.
  Catalogue number.

 Serial number.
  Protected against finger sized objects and against dripping water when tilted up to 15 degrees from specified orientation.
  Humidity limitation.

 Temperature limitation.
  Maximum water level.
  Use distilled water only.

 European RoHS.
  China pollution control logo 1.
  China pollution control logo 2.
  Operating altitude.

Limited warranty

Refer to your device user guide.



ResMed Ltd

1 Elizabeth Macarthur Drive Bella Vista NSW 2153 Australia

See www.resmed.com for other ResMed locations worldwide. For patent information, see www.resmed.com/ip. AirSense, AirCurve, HumidAir, ClimateLine and SlimLine are trademarks of ResMed Ltd. AutoSet, SlimLine and ClimateLine are registered in U.S. Patent and Trademark Office. © 2018 ResMed Ltd. 378145/2 2018-03

ResMed.com

CE 0123



378145